

WALL SLEEVE AND STAMPED EXTERIOR LOUVER INSTALLATION INSTRUCTIONS FOR USE WITH PACKAGED TERMINAL AIR CONDITIONERS **16 1/2" X 40" SLEEVE MODEL SAX99AA40A**

These instructions apply for installation of the wall sleeve only through walls structurally adequate to support the unit (sleeve, chassis, accessories).

Instructions to install a stamped exterior louver (separate accessory) are provided herein. For an architectural extruded louver refer to the instructions packed with the louver.

If wall is not structurally adequate (normally less than nominal 2X4 construction) a subbase must be used. Refer to subbase installation instructions for additional information.

If an internal condensate drain kit is used it must be installed before the wall sleeve is placed in the wall. See instructions provided with drain kit

WALL OPENING

Observe the following:
Maintain a clearance of 3 1/2" above floor covering if possible. The 3 1/2" clearance is necessary if a subbase is used.

CAUTION

Installations with less than 3 1/2" minimum will limit the amount of return air flow and may result in premature compressor failure.

If a hydronic subbase is to be used, the clearance must be 7". See instructions with subbase.
Walls of masonry construction must have a lintel across top of opening, Fig. 5.

WALL DEPTH - 12" Maximum

1. Size and cut the wall opening 3 1/2" minimum above floor as close to 16 3/4" x 40 1/4" as practical. If opening is cut too large, filler strips or excessive caulking will be required.
2. Frame the opening to provide adequate support.

WALL DEPTH - 12" to 18 1/2" Maximum

If wall is thicker than 12" a sheet metal sleeve or a sheet metal drain trough will have to be fabricated, Fig 2. Two air baffles, to separate inlet and outlet air, will also have to be fabricated and fastened to the back side of the wall sleeve or to the stamped exterior louver. Ref. Figs. 3 and 4.

3. Cut opening per steps 1 and 2 after considering all of the following and determining which type of installation is most desirable. If an exterior louver is desired, a way to mount it will have to be provided.

A. If wall is masonry, flanges will have to be provided on the extended sleeve or separate flanges will have to be provided.

B. If wall has exterior siding the size of the opening in the siding can be reduced 1 1/8" on each side and the top to mount louver. Bottom must be cut flush with framed opening.

DRAIN TROUGH, Figs. 2, 3, & 4

Sheet metal drain trough should be sized approximately 41 1/4" long by depth "A" plus 2". Bend a 1/2" -90 degree flange up on each end and a 1 1/2" -70 degree flange down on outside to form a drip edge. Position drain trough in wall opening with 1/4" pitch to outside and secure using silicone sealant or small fasteners near top of end flanges.

WARNING

DANGER OF BODILY INJURY OR DEATH

If opening is cut in an existing wall make sure there is no electrical wiring that can be cut into.

FIG. 1 WALL OPENING

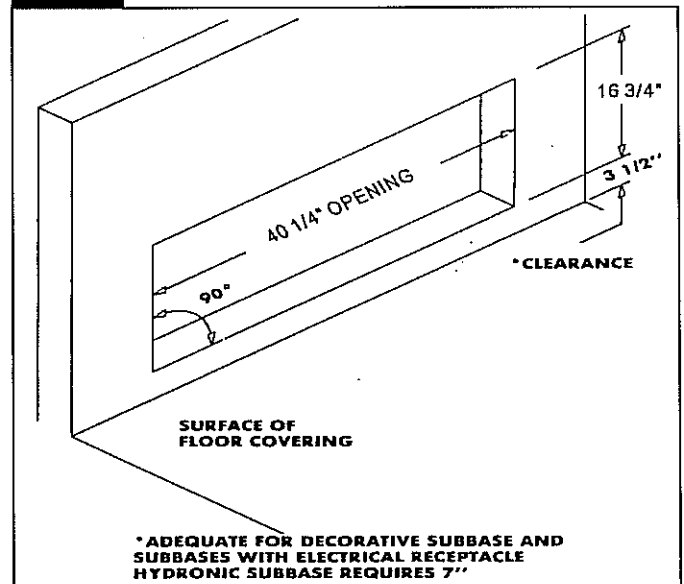

Seal around all edges and fasteners to prevent moisture from getting inside wall.

EXTENDED WALL SLEEVE, Figs. 2, & 3

The wall sleeve extension must be sized to fit in framed opening and over the factory wall sleeve.

It should be formed from at least "A" deep plus 2" to allow a 1 1/2" drip edge on the bottom and a 1" formed flange on the sides and top for mounting of exterior louver.

Position in wall and secure with fasteners through sides and top. DO NOT put fasteners through the bottom.

Seal all around the sleeve to prevent moisture from getting inside the wall.

AIR Baffles

Air baffles should be sized 15 3/4" high by the depth "A" plus 1/2" (for flange) from the sleeve to the outside of the wall opening.

A. For installation on the back of the wall sleeve (using exterior louver) Fig. 2, form two 1/2" flanges on baffle. Position baffles on

FIG. 2 DRAIN TROUGH AND WALL SLEEVE EXTENSION

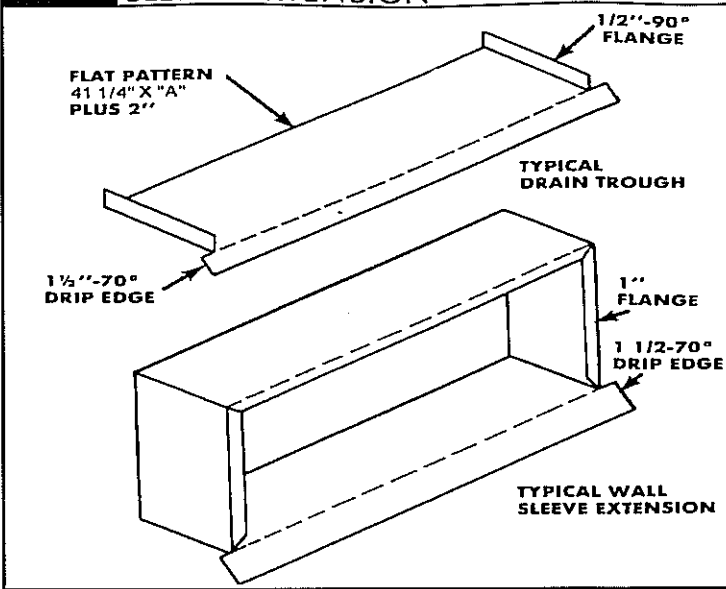
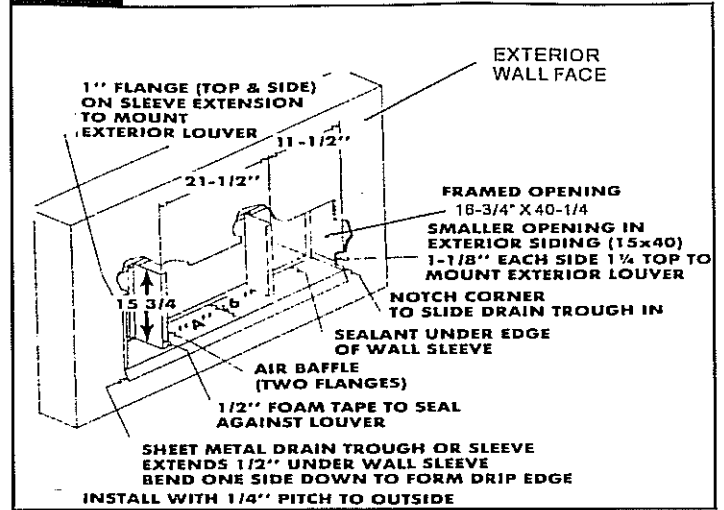

FIG. 3 DEEP WALL WITH EXTERIOR LOUVER ON OUTSIDE OF WALL



the wall sleeve so they are flush with the top and spaced as shown in Fig.3. Drive a screw through the top and bottom of flange into the wall sleeve. Attach 1/2" x 1/2" foam weatherstrip on outside flange to seal against exterior louver.

B. For installation using the stamped louver on the wall sleeve (with no exterior louver on the wall) form a 1/2" flange on the baffle, Fig. 4. Position baffles so they are flush with the top of stamped louver and spaced as shown in Fig. 4. Drive a screw or rivet through the top and bottom of flange into the louver and wall sleeve. Baffles can also be fastened to the louver only using pop rivets or suitable fasteners.

SLEEVE INSTALLATION

1. Install drain kit if used, see instructions with kit.
2. Install exterior louver on wall sleeve. Louver may be installed from outside after sleeve is in the wall, only if the location provides safe working conditions.

A. Position louver on back side of wall sleeve and align mounting holes in perimeter of louver with holes in wall sleeve flanges. Secure using the four screws provided.

3. Position wall sleeve in opening and push through the wall so it protrudes at least 1/2" on the outside. There must be at 7 1/2" of the sleeve (without front panel) on the inside, 9" if a Lateral Duct Plenum is to be used or 10" if a Hydronic Subbase is to be used.

A. If installation is in a deep wall apply a small bead of sealant near the edge of the drain trough or extended wall sleeve before the wall sleeve is put in the opening. The sealant will prevent water from getting under the wall sleeve. After wall sleeve is positioned check to make sure drain holes in the back edge of sleeve are not plugged with sealant.

4. Tilt wall sleeve up on the front edge to provide a min. 1/4" to the outside for proper drainage. Pitch can be determined by using a level or measuring distance from floor as shown in Fig. 5. Check to be sure it is level side to side.

5. Secure wall sleeve to wall with a least four #10x1" screws. Drill two 3/16" holes through each side of the sleeve, one hole near the top and the other at least 4" above the bottom.

NOTE: To prevent water leakage into the room or wall, do not put any screws in the bottom of the wall sleeve.

6. Apply caulking all around the wall sleeve where it projects through the inside and outside wall surfaces.

7. If chassis will be installed later position the protective weatherboard inside the wall sleeve to protect structure.

FIG. 4 DEEP WALL WITH STAMPED LOUVER ON WALL SLEEVE

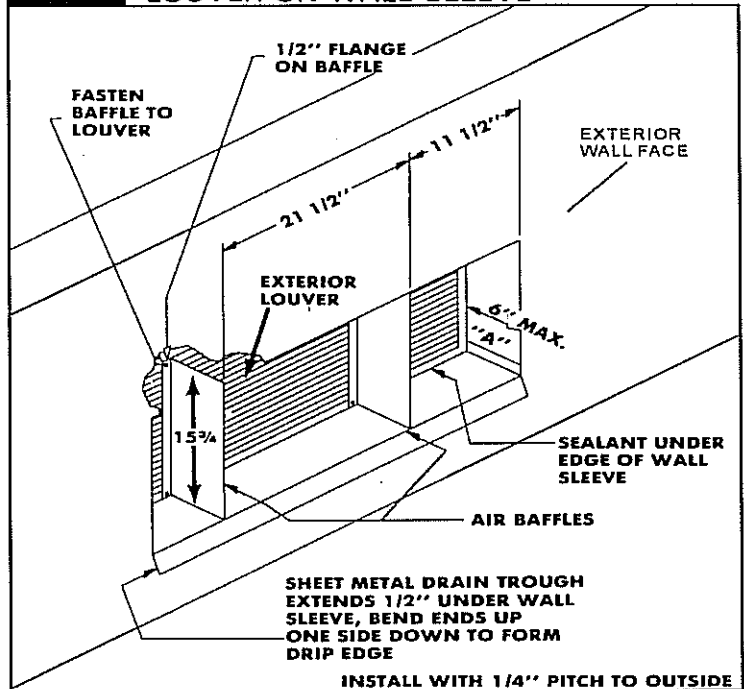

FIG. 5 SLEEVE INSTALLATION

