

NFEC SERIES UPFLOW PACKAGED TERMINAL AIR CONDITIONER (PTAC)

Cooling with Electric Heat

INSTALLATION & OPERATION MANUAL

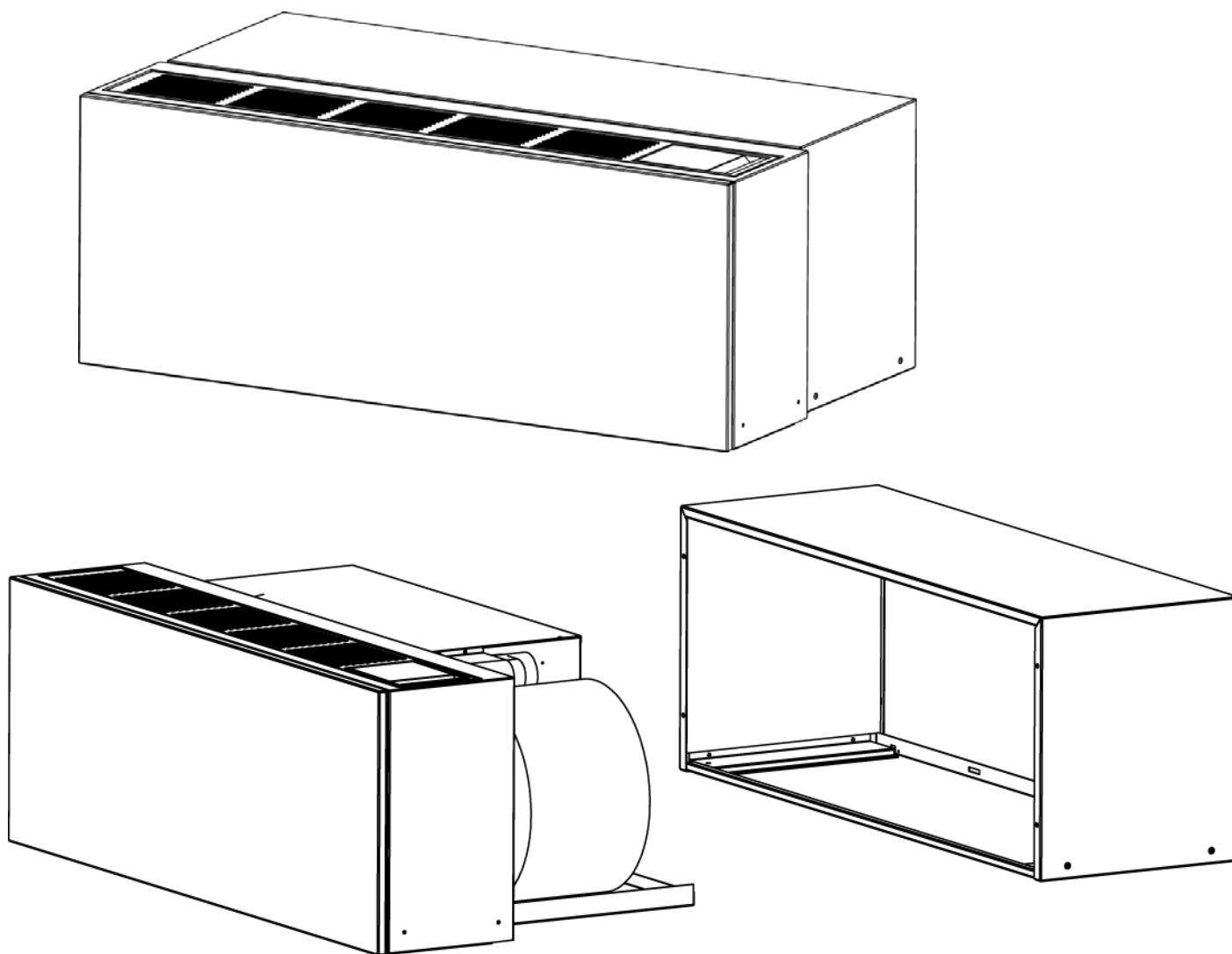

IMPORTANT:

READ AND SAVE THESE INSTRUCTIONS. INSTALLATION AND WIRING MUST BE IN ACCORDANCE WITH CEC, NEC AND LOCAL ELECTRICAL CODES.

NFEC Heat/Cool

GENERAL INFORMATION

This Applied Comfort PTAC is designed and built for through-the-wall installation in either new or existing buildings. The self contained compressor and refrigerant system delivers the cooling, and resistance heaters provide the heating.

WARNING: To avoid property damage, bodily injury or death, ensure power is disconnected before any service is attempted. Repairs should be made by qualified service personnel only. The chassis must be installed in accordance with the Authority Having Jurisdiction, and all Local and National Codes, including the National Electrical Code, and the Canadian Electrical Code, as applicable.

FOR EFFICIENT OPERATION

Air Filter

Keep air intake filter clean. Units are provided with a washable filter that can be cleaned with soap and water. Inspect and clean the filter a least once a month or more often as conditions dictate. Replace as necessary. A dirty, clogged filter reduces the efficiency of the system. It can also cause erratic performance of controls and can result in damage to the motor and compressor.

WARNING: To avoid bodily injury, ensure power is disconnected before removing the air filter, as there will be potential exposure to rotating parts. Always replace the air filter, filter bracket, and screw to close off the bottom of the unit to prevent unintended contact with the blower wheels, before operating the unit.

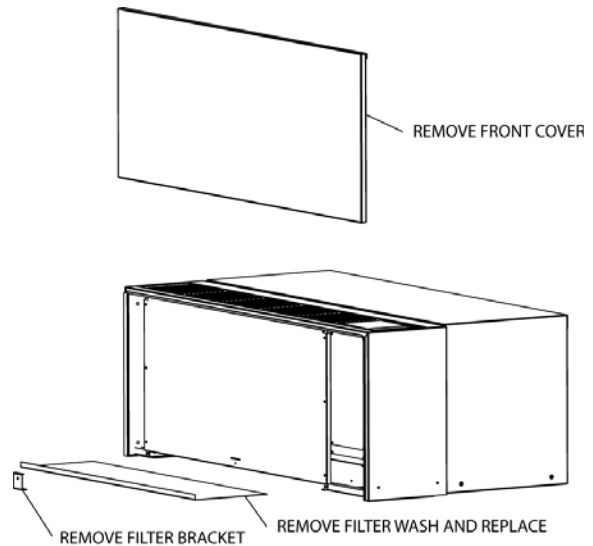

Clean Coils

As part of regular servicing, clean the condenser coil, and evaporator coil at least annually, or more often as dictated by the severity of the particulates and pollutants circulating in the outdoor and indoor operating environments. One suggested method is as follows:

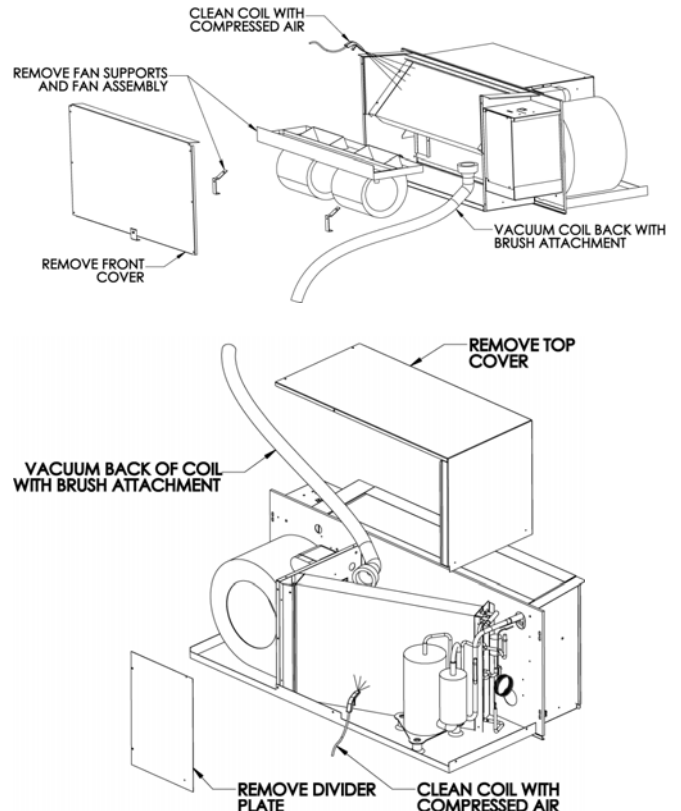

Unimpeded Outdoor Airflow

Do not block off the outside air flow to the unit. The condenser air inlet and outlet must be free of obstructions, and of any external influence that would cause the hot discharged condenser air to be re-circulated back into the condenser air intake. Outdoor air is drawn into the condenser section via the air intake on the right side of the rear grill. Hot condenser air is strongly ejected out of the left portion of the rear grill, thereby minimizing air re-circulation back into the intake areas. Paper, leaves, dirt, or other material blocking airflow, or fouling the condenser coil can impair efficiency and cause serious damage to the compressor.

Oiling

The motors are permanently lubricated and hence need no re-oiling.

Unimpeded Indoor Airflow

Ensure that drapes, bed, bedspread, and furniture etc. do not block the indoor air discharge and intake air openings, causing a restricted air flow condition through the indoor air handling section of the unit. Do not place articles on discharge grille – especially liquids.

Reducing Load

To reduce the cooling load, draw drapes or blinds in the summer, to reflect direct rays from the sun.

To reduce the cooling and heating load, keep windows and doors closed when operating the unit.

WALL SLEEVE CABINET INSTALLATION:

Install the wall sleeve cabinet in strict accordance with the wall sleeve installation instructions, which are supplied with the wall sleeve.

IMPORTANT: The wall sleeve must be installed with a 1/8" per foot slope downward toward the outside to ensure proper water drainage out the back edge of the wall sleeve during overflow conditions. The specified slope corresponds to a 1/8 bubble on a carpenter's level. The wall sleeve must also be level from side-to-side.

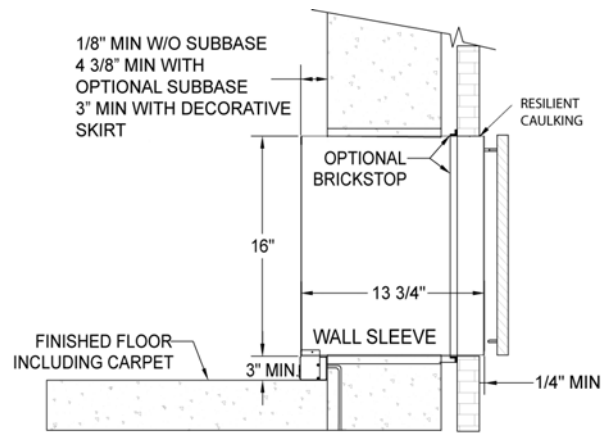

ELECTRICAL WIRING AND RECEPTACLE

WIRE SIZING

A single outlet branch circuit from the main electrical panel to the receptacle in the wall should be used. Wire sizing shall be in accordance with the minimum circuit ampacity as declared on the unit Rating Plate for the specific chassis. Wire sizing must also take into account any distance from fuse box or breaker panel to receptacle to prevent excessive voltage drop in undersized wires.

IMPORTANT: Low voltage to the unit will cause compressor starting problems and decrease the performance and reliability of the compressor.

BRANCH CIRCUIT PROTECTION

The Current Rating of branch circuit protection using a Time Delay Fuse or HACR circuit breaker should also be as declared on the unit Rating Plate for the specific chassis being installed.

PLUG AND RECEPTACLE

230-208 Volt units are furnished with either a NEMA 6-15P, NEMA 6-20P, or NEMA 6-30P, non-locking plug depending on the unit ampacity, and hence will require the corresponding NEMA receptacle to be field-provided.

All 115 Volt units are furnished with a NEMA 5-15P, or 5-20P non-locking plug as applicable. The respective plug will require a NEMA 5-15R or 5-20R receptacle to be field-provided.

All 277 Volt units are furnished with a NEMA 7-20P, 20 Amp non-locking plug and hence will require a NEMA 7-20R receptacle to be field-provided.

NOTE: 277 Volt units are considered to be permanently connected per the National Electrical Code. The plug and cord are considered to be a “connector of convenience” in order to facilitate easy removal of the chassis for servicing. The plug and cord are suitably protected when using either the non-optional 277 volt mechanical sub-base (Part No. ACCNF277SUBBASE) or 277 volt decorative skirt (Part No. ACCNF277SKIRT).

230-208 and 115 volt units are true “cord connected units”, and are provided with a service cord of the LCDI (Leakage Current Detection Interrupter) type, intended to be plugged in to a wall receptacle. The LCDI cord is capable of detecting some of the common faults experienced with aging power cords, and interrupts power to the cord before a hazardous condition can evolve in the cord.

WARNING: To avoid property damage, bodily injury or death, the unit must be used on a grounded power supply only. The unit will be grounded through the service cord plug and matching receptacle as long as the branch circuit remains grounded.

DO NOT:

- Change the length of the service cord.
- Bend the connector blades or otherwise alter service cord plug configuration.
- Use extension cords.

CHASSIS INSTALLATION

Unpack heat/cool chassis from shipping carton. Check for any shipping damage. Spin the fan wheels manually to confirm free rotation. Inspect refrigerant piping to ensure there is no damage or potential chafing. Report any shipping damage to the carrier immediately.

Check the interior of the installed wall sleeve. Clean out any dirt or debris that may have accumulated. Replace air seals that are damaged or missing.

Heating/Cooling Chassis Installation

1. **Locate the wall sleeve seal shipped with the unit and apply it to the top front flange of the wall sleeve, running even with the bottom edge of the flange (see illustration).**

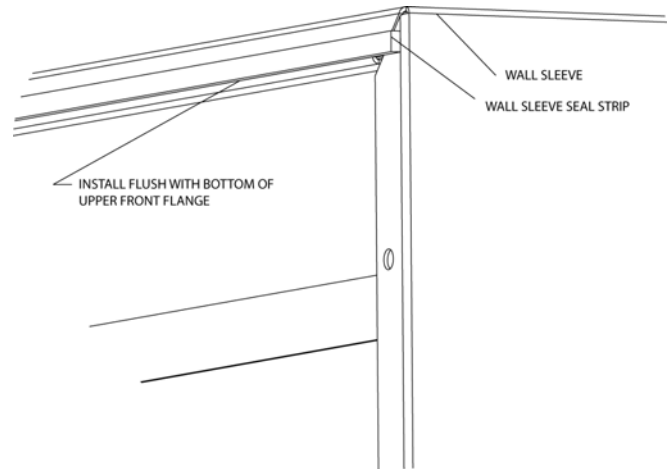

2. Slide the chassis into the wall sleeve until firmly seated against the seals. Push from the ends of the front cover where they attach to the coil supports. Be careful **NOT** to push the chassis from the electrical box cover or middle of the front coil cover.
3. The chassis must be level from side-to-side and sloped toward the outdoors from front-to-rear in the order of 1/8 inch per foot, once the chassis side flanges are drawn up tight to the wall sleeve using the four flange screws. If the sleeve was originally installed with a slope in the bottom of the sleeve in the order of 1/4" per foot downward from the indoor to outdoor side, the chassis will still operate properly. A chassis slope downward (backward toward the room) from outdoor-to-indoor side is not permissible and must be corrected before the unit is operated.
4. There are vertical air seals at the rear of the unit that surround the condenser outlet that will engage and “seal” against the rear grille. However, in some cases, such as when an extra deep wall sleeve is used, or some other variation is encountered that prevents the air deflectors from sealing against the outdoor grille, then steps must be taken to add anti-recirculation baffles to prevent hot condenser air from short-circuiting back into the air intake via the void space created in behind the outdoor grill.
5. Position the chassis in the cabinet and slide into place. Keep the chassis level, square, and centered to prevent binding. The chassis must be pushed into the wall sleeve until the side flange seals of the chassis engage the sleeve. Alternately tighten each of the four

draw screws until the chassis is drawn snugly into the sleeve. Do not over-tighten the draw screws.

6. Locate the 24 Volt wiring harness shipped with the unit. The harness is employed if a remote 24 Volt AC wall thermostat will be used instead of the unit-mounted touchpad. If a 24 volt remote thermostat will be used, connect the multi-wire 24 volt wiring harness to the mating plug protruding beneath the control box, as applicable, following the detailed instructions on the particular wiring diagram affixed to the specific unit being installed. Insulated crimp-on connectors are provided at the end of every connection lead to facilitate connections/insulation.
7. Set the manual damper operator (if present) in the open or closed position depending on the desired operation. If the unit is equipped with a powered damper, it will open and close whenever the indoor fan is operated on high speed, as the factory default.
8. Plug the heat/cool chassis cord into the power receptacle located either in the sub-base or the wall, as applicable.
9. Install the filter and filter bracket/screw, and then slide the front panel downward in the guides in each side of the chassis until it seats.

WARNING: Operating the unit without the filter in place can not only damage the unit, but also expose the user to a hazard from rotating parts, potentially resulting in bodily injury. The filter is intended to be removable with the use of a tool. The filter bracket and screw secure the filter. Always remember to re-install the filter, filter bracket, and screw after servicing the chassis, or replacing/cleaning the filters.

10. Wipe unit cabinet/wall sleeve to remove dirt, etc.
11. The unit is now ready for operation, when supplied with power from the distribution panel and wired to a remote thermostat (if applicable).

START-UP CHECKLIST

Note: Once the unit is installed, it should be checked for proper function by qualified service personnel before turning it over to the User.

- Circuit breakers, wire size, and electrical connections tight and correct
- Filter clean and properly in place

- Condenser air inlet and outlet free of obstructions and no short-circuiting of condenser air
- Unit operated for 20 minutes to prove stability
- Controls operation OK
- Unit installed in compliance with all codes and ordinances
- All panels in place and secured with required fasteners
- Mylar overlay applied to cover up touch pad for 24 Volt Remote Thermostat installations.
- Work area clean and free of debris
- Owner or operator instructed on control operation and routine maintenance.

USER CONTROLS - GENERAL

NFEC series is available with advanced-function electronic controls with membrane switch type keypad.

ELECTRONIC CONTROLS

The chassis incorporating electronic controls is factory-shipped with an active keypad control and display mounted directly to the control panel. The unit functions are controlled by the user by pressing the keys on the keypad, and reading the display. However, the unit also has the latent ability to be field-converted by qualified service personnel for use with a field-supplied 24 volt AC wall thermostat. These instructions will address both unit-mounted control operation, and remote 24 volt AC wall thermostat operation.

CONTROL AT THE UNIT, KEYPAD/DISPLAY

THE KEYPAD CONTROL

Become familiar with the keypad keys as shown in Figure 1.

Display

Red light emitting diodes (LEDs) display the actual temperature of the air entering the unit at floor level. The display can also be used to indicate the desired set point temperature for room comfort. It is important to remember that the temperature displayed is the temperature sensed at the unit's indoor air inlet and can be significantly different from the bulk room temperature at a distance from the unit.

On/Off Key

Each press of the key toggles the unit from an OFF state to an ON state or from an ON state to an OFF state. Heating and cooling functions, as well as the display, and all indicating LEDs except for the fan indicators, are enabled or disabled with this key. When toggled OFF, the control preserves only two modes active; fan-only, and room freeze protection.

Fan Key

Each press of the Fan Key cycles the fan through three modes of operation; Low Speed, High Speed and Auto. Small green LEDs will indicate the mode. The On/Off key need not be ON to operate the fan and set fan speeds. Auto Mode will cycle the fan on and off, and determine the fan speed, in conjunction with the heating or cooling demand.

Warmer Key

Pressing the Warmer Key will cause the display to show the set point temperature for 3 seconds, and then increases room temperature by 1 degree for every subsequent press of the key.

Cooler Key

Pressing the Cooler Key will cause the display to show set point temperature for 3 seconds, and then decreases room temperature by 1 degree for every subsequent press of the key

°F/°C Key

This key toggles the display between Fahrenheit and Celsius temperature modes, and affects all displayed temperatures.

Heat Key

The Heat Key toggles the unit in and out of heating mode for every press of the key, provided the On/Off Key is ON.

Cool Key

The Cool Key toggles the unit in and out of cooling mode for every press of the key, provided the On/Off Key is ON.

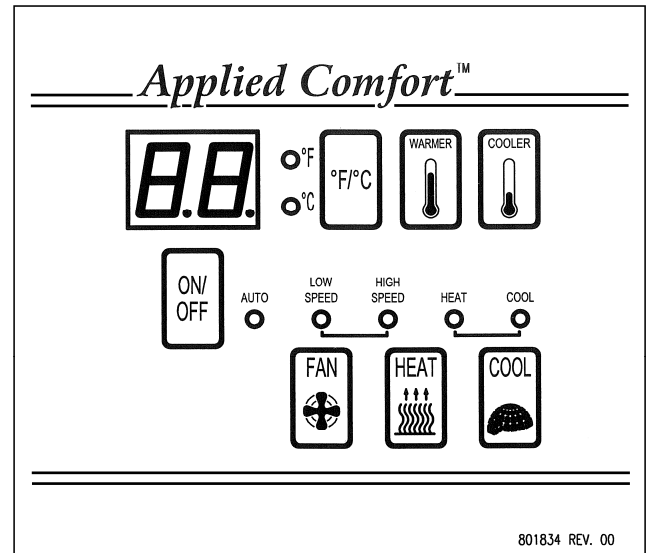

Figure 1

OPERATION USING KEYPAD

When the unit is first plugged in, or when recovering from a power outage, there will be a random 5 to 15 second delay before the electronic control powers up. This minimizes the large electrical surge that would otherwise occur if all units in a building started up at the same time.

To Initiate Heating or Cooling Mode

Press On/Off Key to turn on the LED display and commence full functionality. Push the °F/°C Key to obtain the desired temperature scale. Press the Heat or Cool key as applicable, and the current indoor temperature will be shown on the display.

Set Desired Temperature

Press Cooler or Warmer key as applicable. Each push of the key increases or decreases the set point temperature by 1 degree, as applicable.

Set Fan Mode

Press Fan key to cycle through the fan settings as indicated by the small green circular LEDs. Select continuous High Speed fan, continuous Low Speed fan, or Intermittent Fan by selecting Auto. Auto cycles the fan on and off with the calls for heating or cooling. Auto also sets fan speed according to the amount of heating or cooling demanded. In Auto mode, the fan will start up periodically to establish airflow; air temperature will be sampled, and then the fan will shut off again if there is no demand.

Disable Heating or Cooling, but Initiate Fan-Only
Press On/Off key to turn off LED display. Press Fan key to cycle through the fan settings as indicated by the small circular LEDs. Select continuous High or Low speed. Do not select Auto, as it will turn the fan off.

CONTROL AT THE WALL THERMOSTAT

CONVERSION TO 24V REMOTE THERMOSTAT

Except for the wall thermostat and thermostat cable, everything is included with the unit to field convert a keypad-operated unit to 24 Volt AC wall thermostat operation by qualified service personnel. Specific conversion instructions are detailed on the wiring diagram affixed to each particular unit to be converted. Conversion involves accessing the high voltage wiring compartment and changing a DIP switch setting on the electronic board. Once the DIP switch setting has been changed, operation will be in remote thermostat mode as soon as power is restored to the control.

WARNING: The conversion procedure involves exposure to high voltage electrical circuits in the control box in order to make the necessary change to the DIP switch, and must be performed by qualified service personnel. Failure to do so could result in property damage, personal injury or death. Disconnect electric power to the unit before servicing.

A factory-supplied 24 Volt wiring harness is provided with every unit to facilitate connection to the wall thermostat wiring. One end has a multi-pin connector which mates with a connector exiting the unit. The other end has preinstalled butt splice connectors, which play a dual role in insulating any unused connectors, and can also be used to make the wire connections for wires that are used.

The final step is to apply the masking label provided, to cover up the keypad. The keypad and display will be disabled and no longer be available for control. The masking label markings instruct the user to go to the wall thermostat for controlling the unit.

COMPATIBLE THERMOSTATS

The features of the 24 VAC wall thermostat chosen will dictate the extent of the features available from the unit.

Electric Heat / Cool units can accommodate the following thermostats in either manual or automatic changeover:

- Single Stage Heat/Cool, Single Speed Fan
- Single Stage Heat/Cool, Two Speed Fan

Note: The thermostat selection must be verified to ensure its control logic will always energize a Fan output (G) on a call for heat – also known as an Electric Heat Type Thermostat.

General:

All the above can have single speed or two speed fan control.

The wiring diagrams affixed to the units will guide the specific connection strategies for the particular thermostats used.

THERMOSTAT LOCATION:

Proper functioning of the thermostat depends on accurate room temperature sensing. Be conscious of locating the thermostat where temperatures near the thermostat are not representative of room temperature. For example, do not install the thermostat where it is subjected to direct sunlight, other sources of heat, or to cold drafts, including air discharged from a supply air register. A common error is forgetting to seal the hole in the wall where the thermostat cable passes through, directly behind the thermostat body. Air bleeding from behind the wall can drastically affect the temperature sensed by the thermostat.

REMOTE THERMOSTAT OPERATION

When the unit is first plugged in, or when recovering from a power outage, there will be a random 5 to 15 second delay before the electronic control powers up. The keypad will be totally disabled once the DIP switch has been set for remote mode. The unit will obey the commands from the thermostat only.

The thermostat will automatically maintain the temperature in the room, based on the setting pre-set by the user. If the thermostat has only single fan speed capability, a decision will need to be made as to whether the fan will always run in high speed or low speed, and then the appropriate fan speed wiring connection can be made at the unit.

All the internal control features of the electronic board remain active, except for keyboard and display interface functions and room temperature sampling. Room temperature is detected at the location of the wall thermostat, and is usually a much more accurate representation of bulk room temperature. The thermostat used may have advanced features beyond the basic functions described below. Consult your thermostat Installation and Operating Instructions for further information.

In addition to controlling room temperature, the room thermostat is also used to select whether the unit is to be in heating mode, or cooling mode, or in automatic changeover between the modes. It also determines whether the system is to be ON or OFF, and whether the fan is to run continuously, or to cycle with heating or cooling demand.

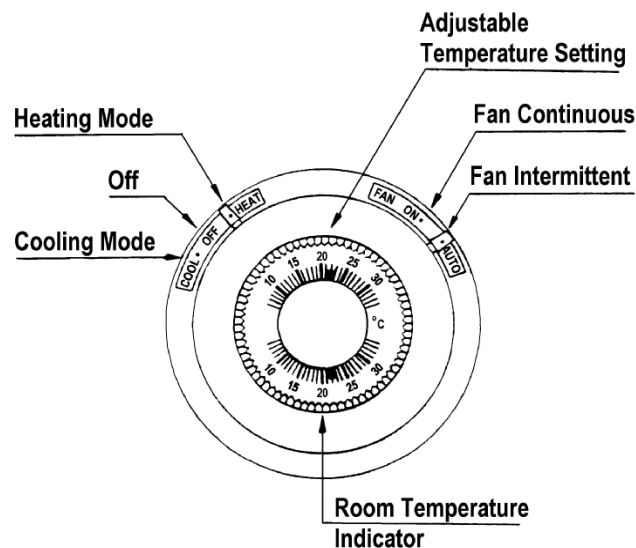

Figure 2

Once a comfortable temperature setting is established, no other adjustments are necessary, except for fan speed, which may or may not be adjustable on your particular thermostat.

CAUTION: One side of the unit's 24-volt control system is grounded. When wiring the thermostat, care must be taken not to ground the wires, or drive a nail through the thermostat wire bundle, thereby potentially burning out the transformer.

WALL THERMOSTAT OPERATION	
Heat	Sets the unit into heating mode. Initiates heating when room temperature falls below set point.
Off	Disables heating and cooling modes, but allows control of fan.
Cool	Sets the unit into cooling mode. Initiates cooling when room temperature rises above set point.
Auto (not shown)	Found on automatic changeover thermostats only. Allows the thermostat to decide whether it should be in the heating or cooling mode. Usually a 4 F° differential or "deadband" will exist between heating and cooling set points to prevent inadvertent rapid switching between modes.
Temperature Setting	Establishes the "set point", or desired room temperature.
Fan On	Synonymous with "Fan Continuous". Fan will continue to run after the heating and cooling function has cycled off. Fan will continue to run even when mode switch is in Off position.
Fan Auto	Synonymous with "Fan Intermittent". Fan will cycle on and off with the heating cycle or cooling cycle, and will not operate between cycles.

ADDITIONAL FEATURES:

Some additional features of the Electronic Control units are as follows:

Room Freeze Protection

This feature is enabled when the unit is shipped from the factory. The feature can be disabled by qualified service personnel. If power is available to the unit, and regardless of whether it is turned ON or OFF, the unit will automatically supply heat to the room with the fan running at low fan speed if the room temperature falls to 50°F (10°C). The heat will turn off when the room temperature reaches 55°F (13°C). For the feature to work, the unit must be configured with an electric heater. The feature is enabled whether the unit is configured for keypad or remote thermostat. The

protection remains active when the unit is OFF, for either keypad or remote thermostat application, as long as the unit is plugged in, power is available, and a heat source is configured in the unit and is working.

Compressor Short-Cycle Protection

If the electronic control shuts the compressor down for any reason, a 3 minute time delay will elapse before the compressor is allowed to re-start. This prevents compressor overload during re-start due to unequal system refrigerant pressures.

Indoor Coil Freeze Protection

Control of frost on the evaporator coil due to low indoor loads, or cold outdoor ambient temperatures, is provided.

Low Outdoor Temperature Lock-out

If the outdoor temperature is too low for proper compressor operation, cooling operation will be suspended until the outdoor temperature rises to an acceptable point, depending on the application.

Indoor Temperature Limiting (Keypad Control Only)

Using the keypad control and display, high and low temperature limits can be established to prevent the user from entering set point temperatures colder or warmer than what the property manager or hotel operator may desire. The temperature limit choices are as follows:

Configuration Code	Low Limit °F (°C)	High Limit °F (°C)
R1	63 (17)	86 (30)
R2	65 (18)	86 (30)
R3	65 (18)	90 (32)
R4	67 (19)	88 (31)
R5	67 (19)	92 (33)
R6	69 (20)	90 (32)
R7	69 (20)	72 (22)

The procedure to set the limits is as follows:

Depress the On/Off key, the °F/°C key, and the Warmer key simultaneously for 5 seconds to enter the limit setup mode. The Warmer and Cooler keys will scroll through the R-values indicated in the above table. Once the desired R-value has been obtained on the display, press the On/Off key to accept the change,

and then press it again to effect the change and restore the normal display.

Automatic Powered Damper

Some units may be provided with an automatic powered fresh air damper that opens the fresh air door to bring outdoor air into the room whenever the indoor fan is running on high speed. If the indoor fan shuts off, the damper automatically closes. The factory default is fresh air with high speed fan operation only, but it can be changed to open with low speed fan operation only by having qualified service personnel re-wire the unit as shown on the specific wiring diagram affixed to the unit.

WARNING: The conversion procedure involves exposure to high voltage electrical circuits in the control box in order to make the necessary change to the damper action tied to motor speed, and must be performed by qualified service personnel. Failure to do so could result in property damage, personal injury or death. Disconnect electric power to the unit before servicing.

OPTIONAL AIR DUCT KIT:

The NFEC series has been designed and certified for use with an optional external duct kit. The kit, in accordance with its installation instructions, requires a Grille Guard to be in place in the indoor air outlet opening of the chassis to prevent unintended contact with the heating elements by the User when reaching through the control door of the duct plenum. The Grille Guard has a low resistance to air flow and is designed for this purpose. It is recommended that only the Applied Comfort Products duct kit be installed on the unit.

The NFEC has been designed to use a 4.5” tall by 7.5” wide insulated (3/8” insulation) Duct Plenum fastened to the top of the unit, which connects to a maximum 48” long insulated (1/4” insulation) Extension Duct of the same size, and uses an Air Terminal Grille at the end of the Extension Duct having an actual outlet area of 7.25”x 4.25” with .125” thick non-adjustable louvers (all provided in the kit). To ensure safe and proper operation it is imperative that all installation instructions shipped

with the duct kit are strictly followed. What is presented in these instructions is a basic overview only.

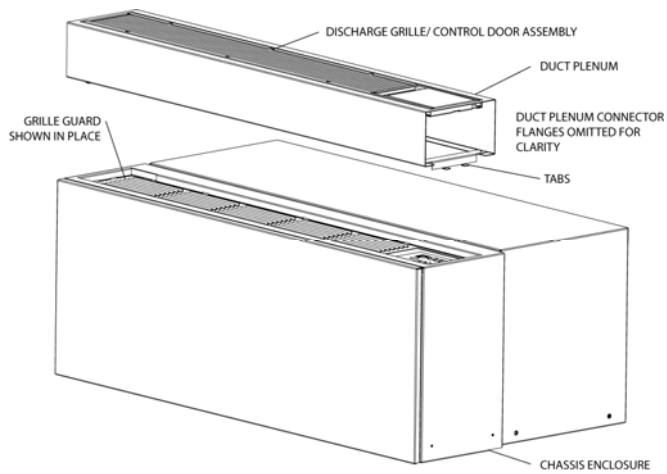

The Duct Plenum is designed to be reversible (shown with right discharge) and is permanently capped at one end. A decision is made whether to duct right or left and the Duct Plenum is positioned with the opening directed accordingly. A strip of blank-off plates (not shown) is supplied with the kit to allow the installer to snap off and adjust the number of active plates required to divert a given amount of air to the adjacent room via the Extension Duct.

Using the maximum number of plates to restrict the plenum outlet opening results in a 60% physical blockage that will divert up to up to 50% of the total air flow to the adjacent room. **To preserve the safety of the design, do not attempt to add additional restriction to exceed the 60% maximum amount of blockage.** The detailed installation instructions shipped with the duct kit will provide more detail regarding percent air diversion relative to number of plates used.

To install the Duct Plenum, the Discharge Grille/Control Door assembly must first be removed from the Chassis Air Outlet by removing the screw located under the control door. Next, lay the Guard Grille/Control Window assembly (shipped with the duct kit) into the Chassis Air Outlet opening with the control window to the right so as to line up with the touchpad control.

WARNING: Risk of personal injury. The Grille Guard/Control Window assembly must be installed in the Chassis Air Outlet opening to properly guard the heaters from unintended contact and to ensure safe operation of the unit.

The Duct Plenum can now be installed. Insert the Duct Plenum tabs into the slots provided in the Chassis Enclosure based on the direction you require the air discharge. On the opposite end of the tabs there will be an existing screw location. Use the screw removed previously to secure the Duct Plenum to the Chassis Air Outlet.

Lay the desired number of blank-off plates into the Duct Plenum in accordance with the kit installation instructions. Re-install The Discharge Grille/Control Door assembly that was removed from the Chassis Air Outlet so that the control door is above the touchpad controls, and secure using the screw provided in the kit. The Discharge Grille/Control Door assembly should now reside in the Duct Plenum outlet if the installation was done correctly.

To complete the assembly, cut the 48" Extension Duct to the desired length, slide it on to the protruding flanges of the Duct Plenum outlet and secure with the two beige screws provided, and then terminate the duct with the Air Terminal Grille by fastening it to the wall in the adjacent room.

To give full access to remove the Chassis at a later date, the Discharge Grille/Control Door assembly can be removed with a single screw to give access to the Duct Plenum, and the Duct Plenum can be removed with a single screw by pulling slightly upward and sideways on the capped end, once the two beige screws have been removed from the duct extension.