

				NAME		DATE		<b>Applied</b> <small>COMFORT</small> TITLE: <b>NA UNIT          BUILD DRAWING</b>	
				DRAWN WWebber		16 Dec 2014			
				CHECKED					
				ENG APPR					
				MFG APPR					
				Q.A.				SIZE DWG. NO. REV <b>G 803859 00</b>	
				MATERIAL		COMMENTS:			
				FINISH					
REV		DATE		NOTES		BY		SCALE: 1:10   WEIGHT:   SHEET 1 OF 6	
APPLICATION				DC		NOT SCALE DRAWING			

**PROPRIETARY AND CONFIDENTIAL**  
 THE INFORMATION CONTAINED IN THIS DRAWING IS THE SOLE PROPERTY OF <INSERT COMPANY NAME HERE>. ANY REPRODUCTION IN PART OR AS A WHOLE WITHOUT THE WRITTEN PERMISSION OF <INSERT COMPANY NAME HERE> IS PROHIBITED.

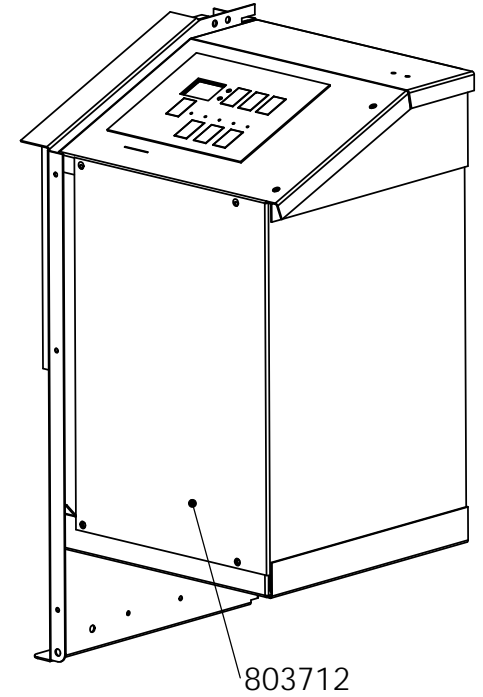
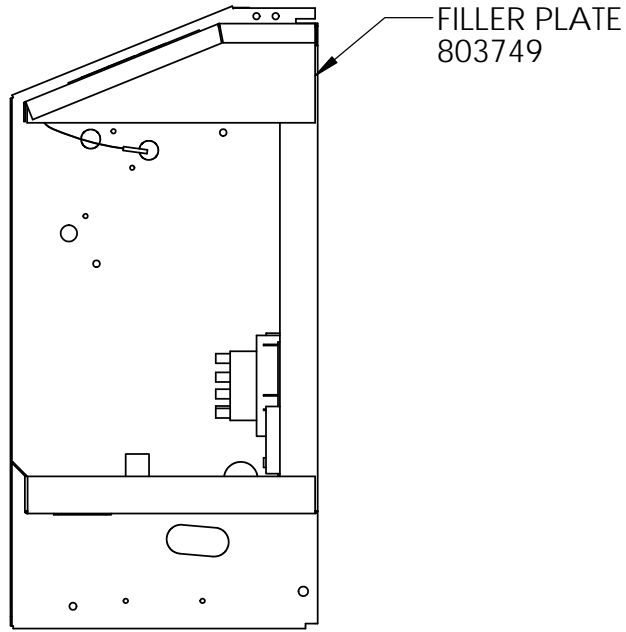
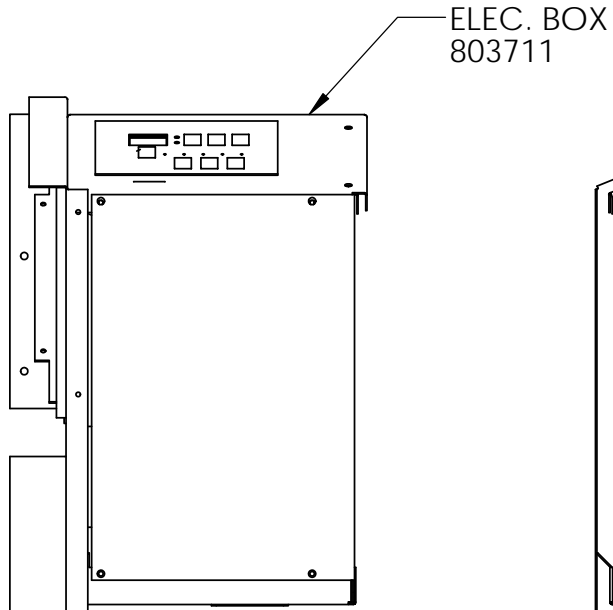

**PROPRIETARY AND CONFIDENTIAL**  
 THE INFORMATION CONTAINED IN THIS DRAWING IS THE SOLE PROPERTY OF <INSERT COMPANY NAME HERE>. ANY REPRODUCTION IN PART OR AS A WHOLE WITHOUT THE WRITTEN PERMISSION OF <INSERT COMPANY NAME HERE> IS PROHIBITED.

					NAME	DATE	Applied COMFORT	
					DRAWN	WWebber		
					CHECKED			TITLE:  ELECTRICAL BOX
					ENG APPR.			
					MFG APPR.			
					Q.A.			
					MATERIAL	COMMENTS:		
					FINISH			
REV	DATE	NOTES	BY	APPLICATION	NOT SCALE DRAWING	SIZE	DWG. NO.	REV
						<b>G</b>	803859	00
						SCALE: 1:5	WEIGHT:	SHEET 2 OF 6

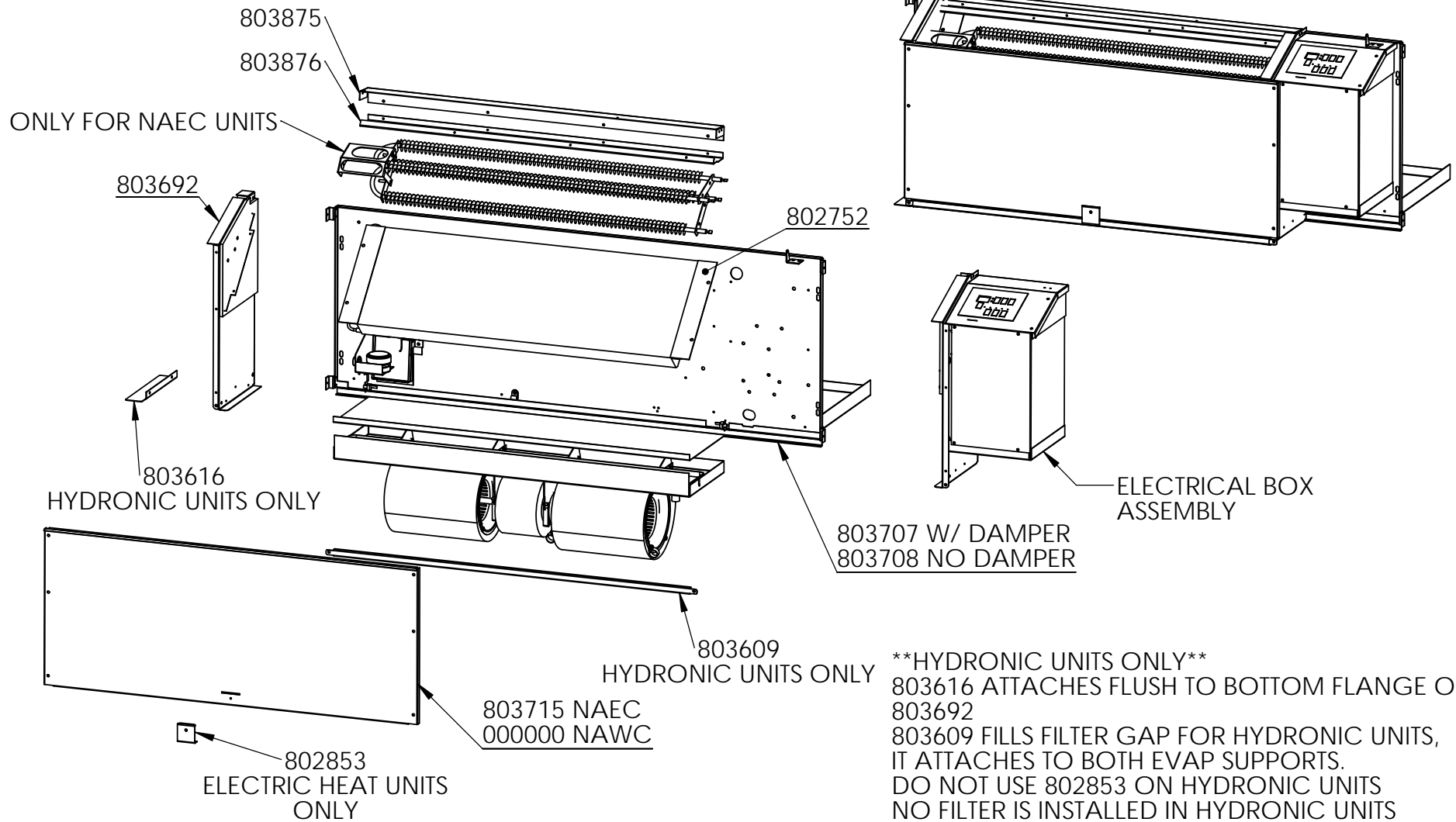

**\*\*HYDRONIC UNITS ONLY\*\***  
 803616 ATTACHES FLUSH TO BOTTOM FLANGE OF 803692  
 803609 FILLS FILTER GAP FOR HYDRONIC UNITS, IT ATTACHES TO BOTH EVAP SUPPORTS.  
 DO NOT USE 802853 ON HYDRONIC UNITS  
 NO FILTER IS INSTALLED IN HYDRONIC UNITS

				NAME		DATE		Applied COMFORT	
				DRAWN WWebber		16 Dec 2014			
				CHECKED				TITLE:  <b>EVAP SECTION</b>	
				ENG APPR					
				MFG APPR					
				Q.A.					
				MATERIAL		COMMENTS:			
				FINISH					
REV	DATE	NOTES	BY						
APPLICATION			DO NOT SCALE DRAWING						

**PROPRIETARY AND CONFIDENTIAL**  
 THE INFORMATION CONTAINED IN THIS DRAWING IS THE SOLE PROPERTY OF <INSERT COMPANY NAME HERE>. ANY REPRODUCTION IN PART OR AS A WHOLE WITHOUT THE WRITTEN PERMISSION OF <INSERT COMPANY NAME HERE> IS PROHIBITED.

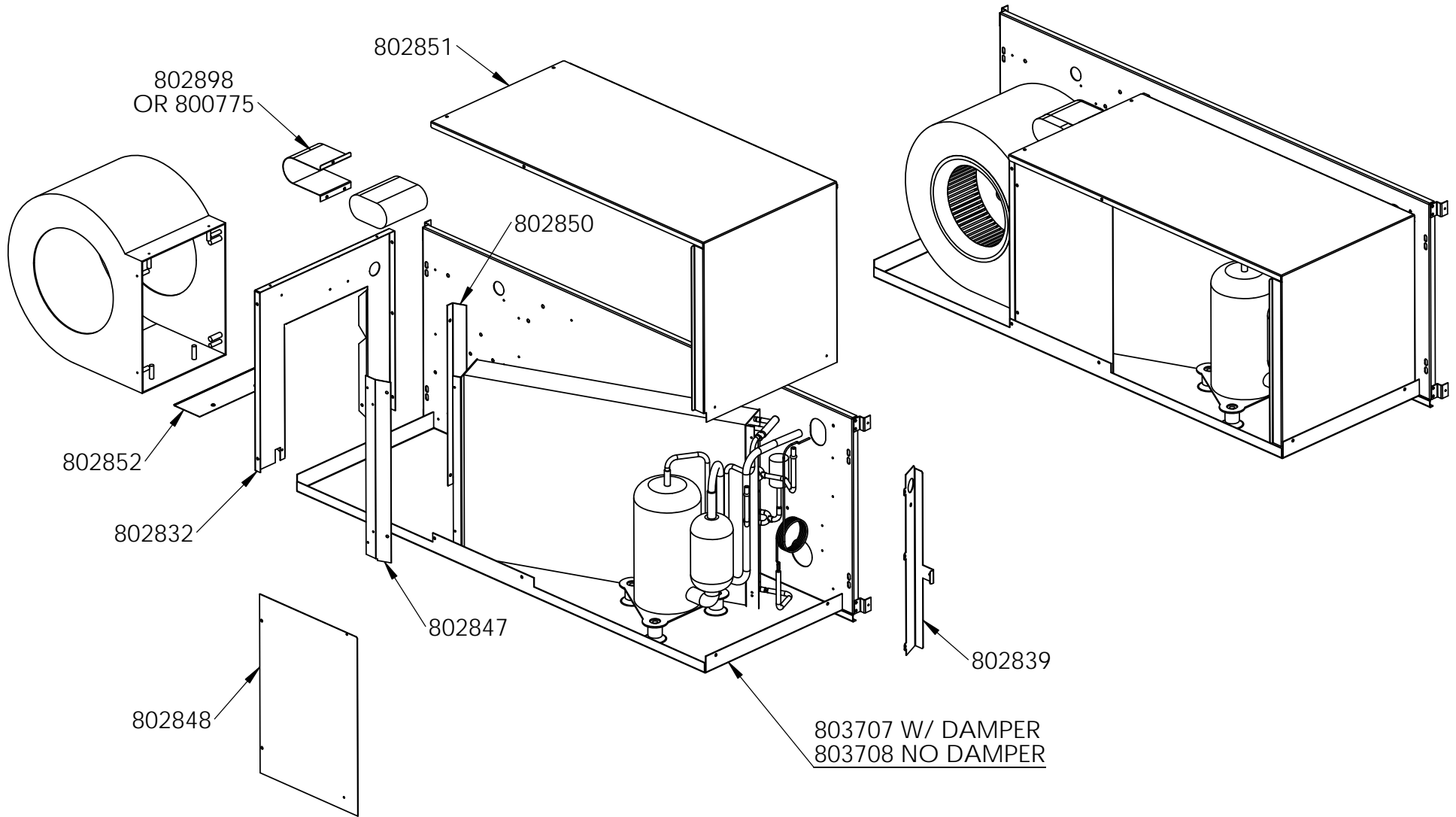

				NAME		DATE		Applied COMFORT	
				DRAWN WWebber		16 Dec 2014			
				CHECKED				TITLE:  CONDENSOR SECTION	
				ENG APPR					
				MFG APPR					
				Q.A.					
				MATERIAL		COMMENTS:			
				FINISH					
REV	DATE	NOTES	BY						
APPLICATION			DO NOT SCALE DRAWING						
SIZE <b>G</b>		DWG. NO. <b>803859</b>			REV <b>00</b>				
SCALE: 1:10		WEIGHT:			SHEET 4 OF 6				

**PROPRIETARY AND CONFIDENTIAL**  
 THE INFORMATION CONTAINED IN THIS DRAWING IS THE SOLE PROPERTY OF <INSERT COMPANY NAME HERE>. ANY REPRODUCTION IN PART OR AS A WHOLE WITHOUT THE WRITTEN PERMISSION OF <INSERT COMPANY NAME HERE> IS PROHIBITED.

2X 802391X6.25  
 APPLY TO INSIDE EDGE OF  
 BOTH EVAP HOLDERS

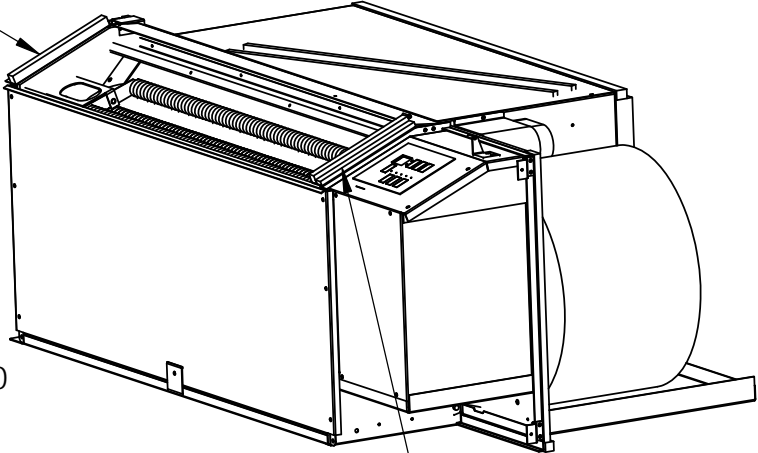

802531X6.25  
 APPLY TO THE OUTSIDE EDGE  
 OF RIGHT HAND EVAP HOLDER

2X 1091637x21.125

53105008X26.75

802547X40

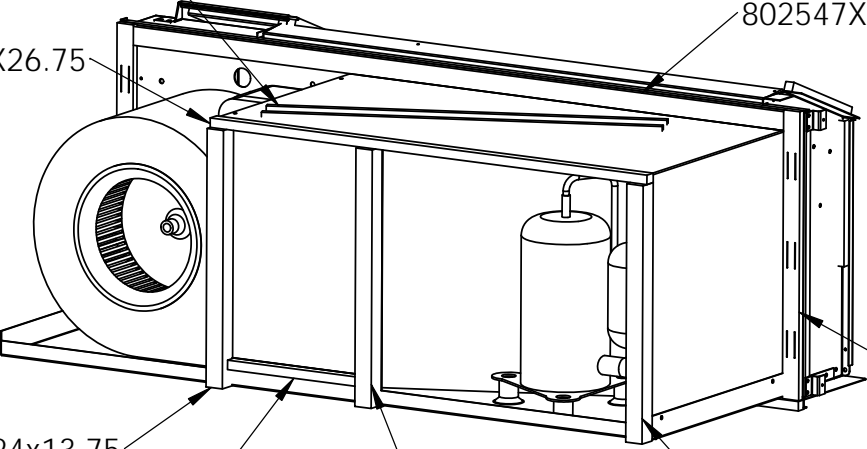

2X 1092013

802024x13.75

53105008X8

802024x13.75

802024x13.75

**PROPRIETARY AND CONFIDENTIAL**  
 THE INFORMATION CONTAINED IN THIS  
 DRAWING IS THE SOLE PROPERTY OF  
 <INSERT COMPANY NAME HERE>. ANY  
 REPRODUCTION IN PART OR AS A WHOLE  
 WITHOUT THE WRITTEN PERMISSION OF  
 <INSERT COMPANY NAME HERE> IS  
 PROHIBITED.

					NAME	DATE	
					DRAWN WWebber	16 Dec 2014	
					CHECKED		
					ENG APPR		
					MFG APPR		
					Q.A.		
					MATERIAL	COMMENTS:	
					FINISH		
REV	DATE	NOTES	BY	APPLICATION			DO NOT SCALE DRAWING

<b>Applied</b> <small>COMFORT</small>		
TITLE:		
<b>SEAL STRIPS</b>		
SIZE	DWG. NO.	REV
<b>G</b>	<b>803859</b>	<b>00</b>
SCALE: 1:10	WEIGHT:	SHEET 5 OF 6

DOOR SUPPORT #803721  
 ATTACHES TO ELEC BOX TOP  
 USING 2X 800705 BLACK OXIDE  
 SCREWS

803695

800378

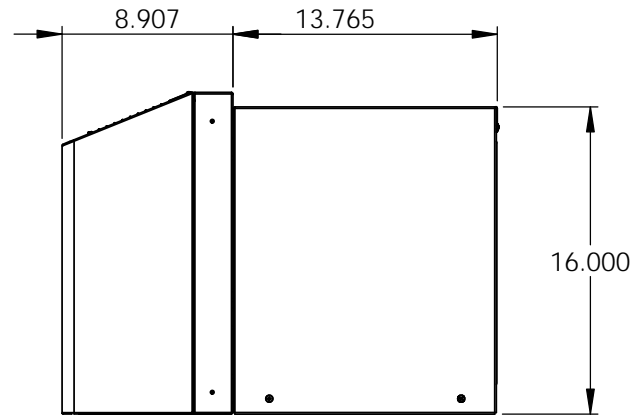
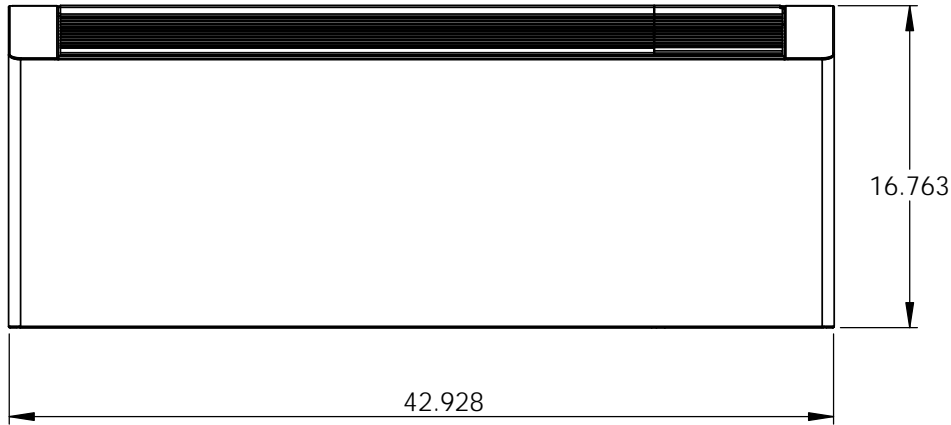
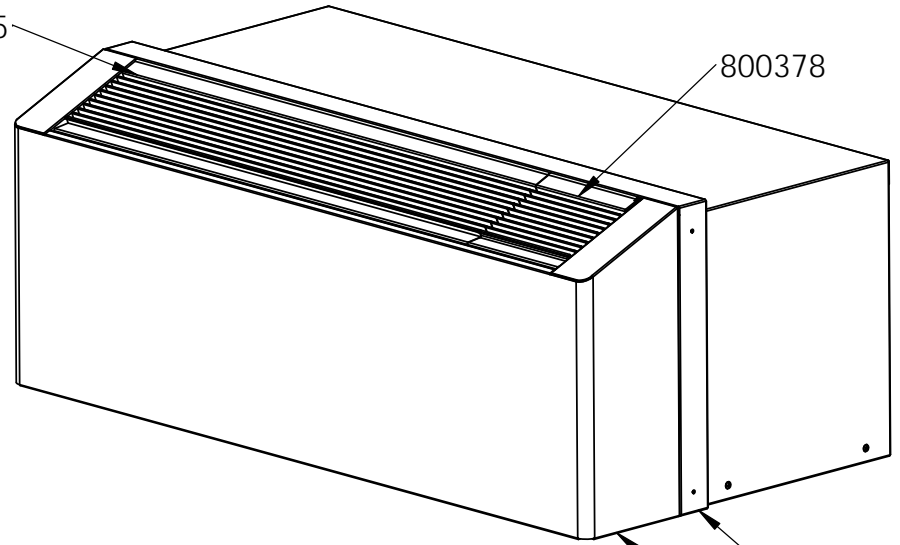

**PROPRIETARY AND CONFIDENTIAL**  
 THE INFORMATION CONTAINED IN THIS  
 DRAWING IS THE SOLE PROPERTY OF  
 <INSERT COMPANY NAME HERE>. ANY  
 REPRODUCTION IN PART OR AS A WHOLE  
 WITHOUT THE WRITTEN PERMISSION OF  
 <INSERT COMPANY NAME HERE> IS  
 PROHIBITED.

				NAME		DATE		Applied COMFORT			
				DRAWN WWebber		16 Dec 2014					
				CHECKED				TITLE:  NA WITH ROOM ENCLOSURE			
				ENG APPR							
				MFG APPR							
				Q.A.							
				MATERIAL		COMMENTS:					
				FINISH							
REV	DATE	NOTES	BY								
APPLICATION			DO NOT SCALE DRAWING								
SIZE <b>G</b>		DWG. NO. 803859			REV 00		SCALE: 1:10			WEIGHT:	SHEET 6 OF 6