

TYPE J INCREMENTAL PACKAGED TERMINAL AIR CONDITIONERS

Electric or Hydronic heating and Cooling Unit
Cooling - Only Unit

INSTALLATION & OPERATION MANUAL

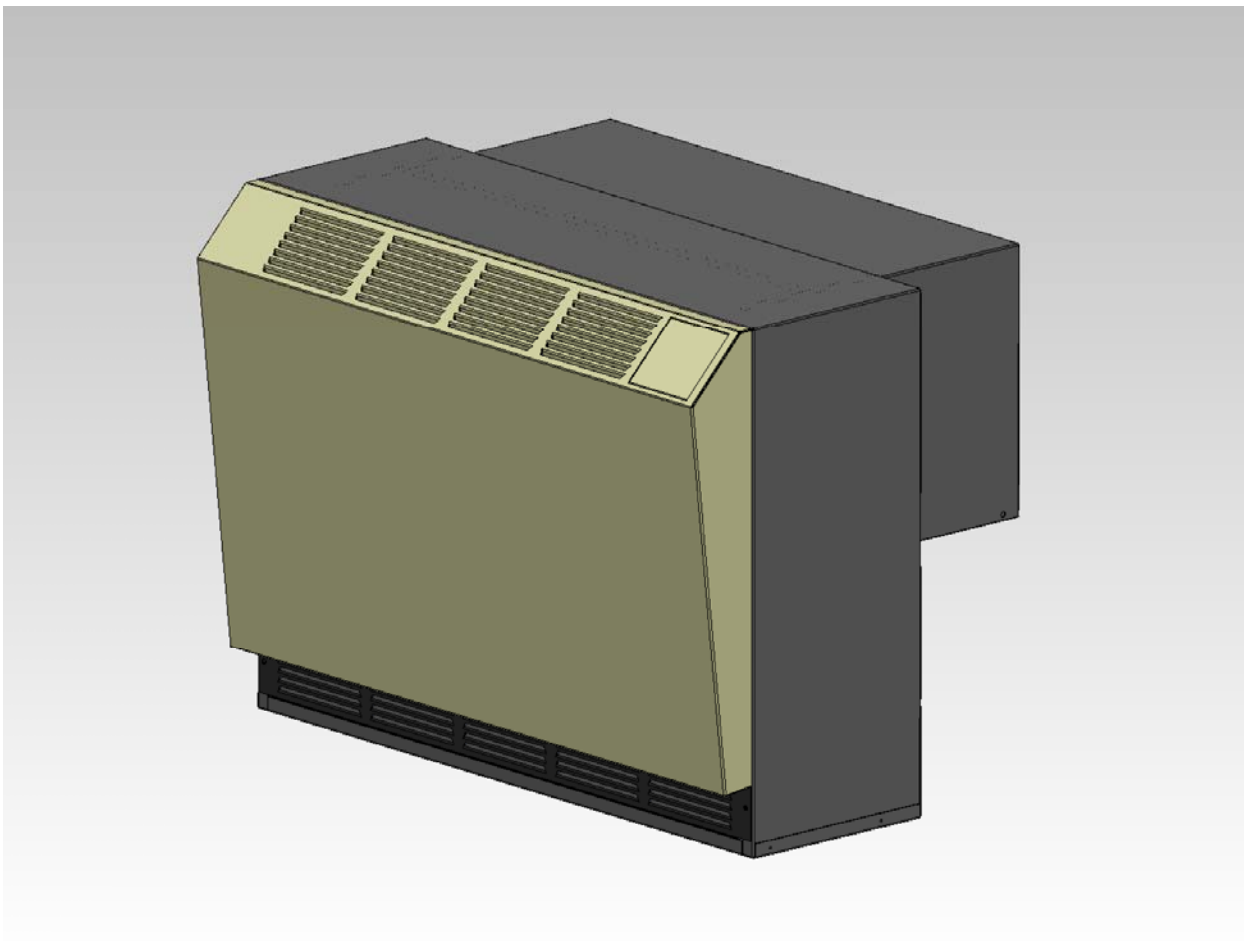

IMPORTANT:

READ AND SAVE THESE INSTRUCTIONS. INSTALLATION AND WIRING MUST BE IN ACCORDANCE WITH CEC, NEC AND LOCAL ELECTRICAL CODES.

JEC/JWC Series

Cooling with Electric OR Hydronic Heat and Cooling-only Chassis, Permanently Connected, wired direct

GENERAL INFORMATION

WARNING: To avoid property damage, bodily injury or death, ensure power is disconnected before any service is attempted. Repairs should be made by qualified service personnel only. The chassis must be installed in accordance with the Authority Having Jurisdiction, and all Local and National Codes, including the National Electrical Code, and the Canadian Electrical Code, as applicable.

FOR EFFICIENT OPERATION

Air Filter

Keep air intake filter clean. Units are provided with a washable filter that can be cleaned with soap and water. Inspect and clean the filter at least once a month or more often as conditions dictate. Replace as necessary. A dirty, clogged filter reduces the efficiency of the system. It can also cause erratic performance of controls and can result in damage to the motor, heating element and compressor.

Filter Removal

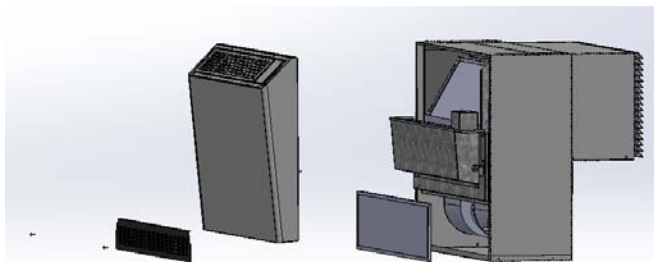

Remove two screws from the indoor return grille and remove grille. Remove room enclosure by unlocking lower tabs. Lift filter out of filter sleeve and wash. After filter is dry place it back in sleeve and attach room enclosure and grille using the two screws. DO NOT run unit while filter is not installed.

IMPORTANT: An improperly maintained filter, or not using a filter, will void the warranty.

Clean Coils

As part of regular servicing, clean the condenser and evaporator coils at least annually, or more often as dictated by the severity of the particulates and pollutants circulating in the outdoor and indoor operating environments. One suggested method is as follows:

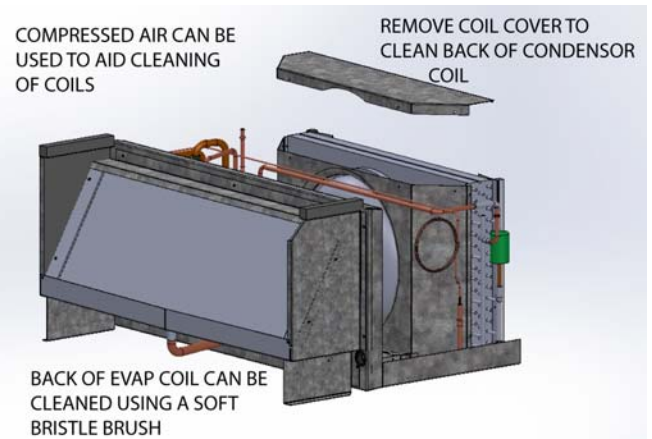

Unimpeded Outdoor Airflow

Do not block off the outside air flow to the unit. The condenser air inlet and outlet must be free of obstructions, and of any external influence that would cause the hot discharged condenser air to be re-circulated back into the air intakes. Outdoor air is drawn into the condenser section via air intakes on the right and left sides of the rear grill. Hot condenser air is strongly ejected out of the center portion (approximately) of the rear grill, thereby minimizing air recirculation back into the intake areas. Paper, leaves, dirt, or other material blocking airflow, or fouling the condenser coil can impair efficiency and cause serious damage to the compressor.

Oiling

The motors are permanently lubricated and do not require re-oiling.

Unimpeded Indoor Airflow

Ensure that drapes, bed, bedspread, and furniture etc. do not block the indoor air discharge and intake air openings, causing a restricted air flow condition through the indoor air handling section of the unit. Do not place articles on discharge grille – especially liquids.

Reducing Load

To reduce the cooling load, draw drapes or blinds in the summer, to reflect direct rays from the sun.

To reduce the cooling and heating load, keep windows and doors closed when operating the unit.

WALL SLEEVE CABINET INSTALLATION:

Install the wall sleeve cabinet in strict accordance with the wall sleeve installation instructions, which are supplied with the wall sleeve.

ELECTRICAL WIRING AND RECEPTACLE

WIRE SIZING

A single outlet branch circuit from the main electrical panel to the receptacle in the subbase should be used. Wire sizing shall be in accordance with the minimum circuit ampacity as declared on the unit Rating Plate for the specific chassis. Wire sizing must also take into account any distance from fuse box to receptacle to prevent excessive voltage drops in undersized wires.

IMPORTANT: Low voltage to the unit will cause compressor starting problems and decrease the performance and reliability of the compressor.

BRANCH CIRCUIT PROTECTION

The Current Rating of branch circuit protection using a Time Delay Fuse or HACR circuit breaker should also be as declared on the unit Rating Plate, for the specific chassis being installed.

IMPORTANT:

Original equipment J chassis were supplied as hard wired units Applied Comfort units are also supplied hard wired only

WARNING: To avoid property damage, bodily injury or death, the unit must be used on a grounded power supply only. The unit will be grounded through the service cord plug and matching receptacle as long as the branch circuit remains grounded.

Electric Power Wiring For hard wired units

An electrical junction box is located on the bottom of the wall sleeve. Field wiring should be brought to this point for power to the unit. Be careful to ensure all wiring is done in accordance with the authority having jurisdiction. All local and National Electrical codes, and the Canadian Electrical Code must be followed.

WARNING: To avoid property damage, bodily injury or death, the unit must be used on a grounded power supply only.

CHASSIS INSTALLATION



1. SEE INDIVIDUAL INSTALATION INSTRUCTIONS FOR EACH ACCESSORY DISCONNECT POWER BEFORE INSTALLING OR MAINTAINING ANY PART OF THE PTAC UNIT
2. Basic generic instructions are as follows Unpack heat/cool chassis from shipping carton. Check for any shipping damage.
3. Check the condition of the air seals at the rear (outdoor side) of the wall sleeve and edges of the dividing wall. It is important to replace them if they are damaged or missing. For this chassis, the weather sealing between the chassis and wall sleeve occurs at the dividing wall. The edges around the perimeter of the dividing wall are squeezed into the seals at the top and side of the sleeve by compressive force. A downward slope, with the indoor side being higher than the outdoor, in the range of approximately 1/8" per foot, should occur if the wall sleeve and unit are properly installed.
4. At each end of the condenser coil, there are vertical air deflectors with foam seals applied to them that will engage and "seal" against the rear grille. However, in some cases, such as when an extra deep wall sleeve is used, or some other variation is encountered that prevents the air deflectors from sealing against the outdoor grille, then steps must be taken to add anti-recirculation baffles to prevent hot condenser air from short-circuiting back into the air intakes via the void spaces apparent in behind the outdoor grill.
5. Install the heating compartment following the instruction manual provided with the individual heating assembly. Electric resistance heating assemblies come pre-wired with a molex connector that will attach to a harness supplied with the electrical box. Hydronic heating assemblies will require piping attachments and should be installed by qualified contractors.
6. Install the fan compartment following the instructions provided with the fan assembly. The fan assembly will connect to the back of the electrical box via a provided molex connector.
7. Install the electrical box compartment following the instructions provided with the electrical box assembly. The electrical box assembly requires connections to be made to existing power from the building. This must be done by qualified personnel following all relevant building and

electrical codes. Failure to do so could cause property damage, bodily injury or death.

8. Install the room enclosure following the instructions provided in the room enclosure box. This will be the last step to installation process.

WARNING: Operating the unit without the front panel in place exposes the user to a hazard from rotating parts, potentially resulting in bodily injury. The front panel is intended to be removable only with the use of tools. Always remember to re-install the return grille retaining screws in the bottom corners of the grille after servicing the chassis.

9. Wipe unit cabinet/wall sleeve to remove dirt, etc.
10. The unit is now ready for operation, when supplied with power from the distribution panel and wired to a remote thermostat (if applicable).
- 11.

START-UP CHECKLIST

Note: Once the unit is installed, it should be checked for proper function by qualified service personnel before turning it over to the User.

- Circuit breakers, wire size, and electrical connections tight and correct
- Filter clean and properly in place
- Condenser air inlet and outlet free of obstructions and short-circuiting of condenser air
- Unit operate for 20 minutes to prove stability
- Controls operation OK
- Unit installed in compliance with all codes and ordinances
- All panels in place and secured with required fasteners
- Mylar overlay applied to cover up touch pad for 24 Volt Remote Thermostat installations.
- Work area clean and free of debris
- Owner or operator instructed on control operation and routine maintenance.

USER CONTROLS - GENERAL

The chassis incorporates electronic controls which are factory-shipped with an active keypad control and display. The J chassis is designed to allow for unit controls to be mounted directly to the room enclosure. The control box is mounted to the room enclosure after the grill has been installed. Mount the control box under the grill using 4 -1/2" long screws and the existing holes in the grill assembly. See room enclosure installation manual for more detailed instructions. Unit functions are controlled by the user by pressing the keys on the keypad, and reading the display. However, the unit also has the latent ability to be field-converted by qualified service personnel for use with a field-supplied 24 volt AC wall thermostat. These instructions will address both unit-mounted control operation, and remote 24 volt AC wall thermostat operation.

CONTROL AT THE UNIT, KEYPAD/DISPLAY

THE KEYPAD CONTROL

Become familiar with the keypad keys as shown in Figure 1.

Display

Red light emitting diodes (LEDs) display the actual temperature of the air entering the unit at floor level. The display also can also be used to indicate the desired set point temperature for room comfort. It is important to remember that the temperature displayed is the temperature sensed at the unit's indoor air inlet and can be significantly different from the bulk room temperature at a distance from the unit.

On/Off Key

Each press of the key toggles the unit from an OFF state to an ON state or from an ON state to an OFF state. Heating and cooling functions, as well as the display, and all indicating LEDs except for the fan indicators, are enabled or disabled with this key. When toggled OFF, the control preserves only two modes active; fan-only, and room freeze protection.

Fan Key

Each press of the Fan Key cycles the fan through three modes of operation; Low Speed, High Speed and Auto. Small LEDs will indicate the mode. The On/Off key need not be ON to operate the fan and set fan speeds. Auto Mode will cycle the fan on and off, and determine the fan speed, in conjunction with the heating or cooling demand.

Warmer Key

Pressing the Warmer Key will cause the display to show the set point temperature for 3 seconds, and then increases room temperature by 1 degree for every subsequent press of the key.

Cooler Key

Pressing the Cooler Key will cause the display to show set point temperature for 3 seconds, and then decreases room temperature by 1 degree for every subsequent press of the key.

°F/°C Key

This key toggles the display between Fahrenheit and Celsius temperature modes, and affects all displayed temperatures.

Heat Key

The Heat Key toggles the unit in and out of heating mode for every press of the key, provided the On/Off Key is ON.

Cool Key

The Cool Key toggles the unit in and out of cooling mode for every press of the key, provided the On/Off Key is ON.

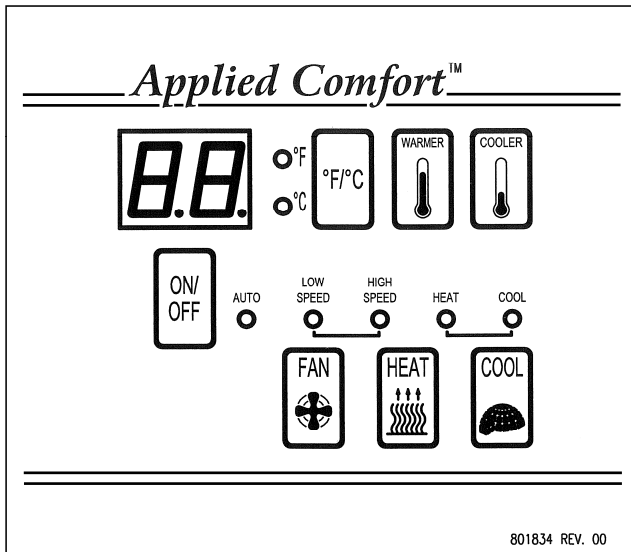

Figure 1

OPERATION USING KEYPAD

When the unit is first plugged in, or when recovering from a power outage, there will be a random 5 to 15 second delay before the electronic control powers up. This minimizes the large electrical surge that would otherwise occur if all units in a building started up at the same time.

To Initiate Heating or Cooling Mode

Press On/Off Key to turn on the LED display and commence full functionality. Push the °F/°C Key to obtain the desired temperature scale. Press the Heat or Cool key as applicable, and the current indoor temperature will be shown on the display.

Set Desired Temperature

Press Cooler, or Warmer key as applicable. Each push of the key increases or decreases the set point temperature by 1 degree, as applicable.

Set Fan Mode

Press Fan key to cycle through the fan settings as indicated by the small circular LEDs. Select continuous High Speed fan, continuous Low Speed fan, or Intermittent Fan by selecting Auto. Auto cycles the fan on and off with the calls for heating or cooling. Auto also sets fan speed according to the amount of heating or cooling demanded. In Auto mode, the fan will start up periodically to establish airflow; air temperature will be sampled, and then the fan will shut off again if there is no demand.

Disable Heating or Cooling, but Initiate Fan-Only

Press On/Off key to turn off LED display. Press Fan key to cycle through the fan settings as indicated by the small circular LEDs. Select continuous High or Low speed. Do not select Auto, as it will turn the fan off.

CONTROL AT THE WALL THERMOSTAT

CONVERSION TO 24V REMOTE THERMOSTAT

Except for the wall thermostat and thermostat cable, everything is included with the unit to field convert a keypad-operated unit to 24 Volt AC wall thermostat operation by qualified service personnel. Specific conversion instructions are detailed on the wiring diagram affixed to each particular unit to be converted. Conversion involves accessing the high voltage wiring compartment and changing a DIP switch setting on the electronic board. Once the DIP switch setting has been changed, operation will be in remote thermostat mode as soon as power is restored to the control.

WARNING: The conversion procedure involves exposure to high voltage electrical circuits in the control box in order to make the necessary change to the DIP switch, and must be performed by qualified service personnel. Failure to do so could result in property damage, personal injury or death. Disconnect electric power to the unit before servicing.

A factory-supplied 24 Volt wiring harness is provided with every unit to facilitate connection to the wall thermostat wiring. One end has a multi-pin connector that mates with a connector exiting the unit. The other end has preinstalled butt splice connectors, which play a dual role in insulating any unused connectors, and can also be used to make the wire connections for wires that are used.

The final step is to apply the masking label provided, to cover up the keypad. The keypad and display will be disabled and no longer be available for control. The masking label markings instruct the user to go to the wall thermostat for controlling the unit.

COMPATIBLE THERMOSTATS

The features of the 24 VAC wall thermostat chosen will dictate the extent of the features available from the unit.

Electric Heat / Cool and Cooling-only

The following thermostats in either manual or automatic changeover may be used:

- Single Stage Heat/Cool, Single Speed Fan
- Single Stage Heat/Cool, Two Speed Fan

Note: For full functional capability, the thermostat selection must be verified to ensure its control logic will always energize a Fan output (G) as well as the heating output (W) on a call for heat – otherwise known as an “Electric Heat Type Thermostat”. If the thermostat to be used has a “W”

output only on a call for heat, consult the specific wiring diagram affixed to the chassis control box for the remedial around instructions.

The thermostats listed above can have single speed or two speed fan control.

The wiring diagrams affixed to the units will guide the specific connection strategies for the particular thermostats used.

THERMOSTAT LOCATION:

Proper functioning of the thermostat depends on accurate room temperature sensing. Be conscious of locating the thermostat where temperatures near the thermostat are not representative of room temperature. For example, do not install the thermostat where it is subjected to direct sunlight, other sources of heat, or to cold drafts, including air discharged from a supply air register. A common error is forgetting to seal the hole in the wall where the thermostat cable passes through, directly behind the thermostat body. Air bleeding from behind the wall can drastically affect the temperature sensed by the thermostat.

REMOTE THERMOSTAT OPERATION

When the unit is first plugged in, or when recovering from a power outage, there will be a random 5 to 15 second delay before the electronic control powers up. The keypad will be totally disabled once the DIP switch has been set for remote mode. The unit will obey the commands from the thermostat only.

The thermostat will automatically maintain the temperature in the room, based on the setting pre-set by the user. If the thermostat has only single fan speed capability, a decision will need to be made as to whether the fan will always run in high speed or low speed, and then the appropriate fan speed wiring connection can be made a the unit.

All the internal control features of the electronic board remain active, except for keyboard and display interface functions and room temperature sampling. Room temperature is detected at the location of the wall thermostat, and is usually a much more accurate representation of bulk room temperature. The thermostat used may have advanced features beyond the basic functions described below. Consult your thermostat Installation and Operating Instructions for further information.

In addition to controlling room temperature, the room thermostat is also used to select whether the unit is to be in heating mode, or cooling mode, or in automatic changeover between the modes. It also determines whether the system is to be ON or OFF, and whether the fan is to run continuously, or to cycle with heating or cooling demand.

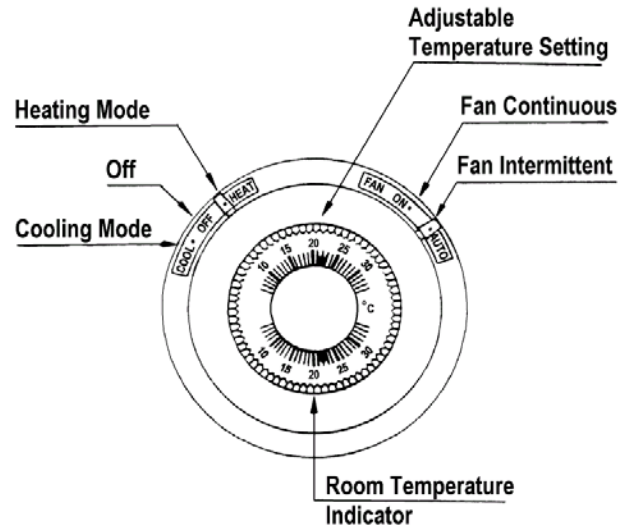

Once a comfortable temperature setting is established, no other adjustments are necessary, except for fan speed, which may or may not be adjustable on your particular thermostat.

CAUTION: One side of the unit’s 24-volt control system is grounded. When wiring the thermostat, care must be taken not to ground the wires, or drive a nail through the thermostat wire bundle, thereby potentially burning out the transformer.

WALL THERMOSTAT OPERATION	
Heat	Sets the unit into heating mode. Initiates heating when room temperature falls below set point.
Off	Disables heating and cooling modes, but allows control of fan.
Cool	Sets the unit into cooling mode. Initiates cooling when room temperature rises above set point.
Auto (not shown)	Found on automatic changeover thermostats only. Allows the thermostat to decide whether it should be in the heating or cooling mode. Usually a 4 F° differential or “deadband” will exist between heating and cooling set points to prevent inadvertent rapid switching between modes.
Temperature Setting	Establishes the “set point”, or desired room temperature.
Fan On	Synonymous with “Fan Continuous”. Fan will continue to run after the heating and cooling function has cycled off. Fan will continue to run even when mode switch is in Off position.
Fan Auto	Synonymous with “Fan Intermittent”. Fan will cycle on and off with the heating cycle or cooling cycle, and will not operate between cycles.

ADDITIONAL FEATURES:

Some additional features of the Electronic Control units are as follows:

Room Freeze Protection

This feature is enabled when the unit is shipped from the factory. The feature can be disabled by qualified service personnel. If power is available to the unit, and regardless of whether it is turned ON or OFF, the unit will automatically supply heat to the room with the fan running at low fan speed if the room temperature falls to 55°F. The heat will turn off when the room temperature reaches 60°F. For the feature to work, the unit must be configured with a heat source, whether it be electric heater, heat pump with electric heat, or hydronic (hot water would need to be standing by). The feature is enabled whether the unit is configured for keypad or remote thermostat.

Compressor Short-Cycle Protection

If the electronic control shuts the compressor down for any reason, a 3 minute time delay will elapse before the compressor is allowed to re-start. This prevents compressor overload during re-start due to unequal system refrigerant pressures.

Indoor Coil Freeze Protection

Control of frost on the evaporator coil due to low indoor loads, or cold outdoor ambient temperatures, is provided. The protection remains active when the unit is OFF, for either keypad or remote thermostat application, as long as the unit is plugged in, power is available, and a heat source is configured in the unit and is working.

Low Outdoor Temperature Lock-out

If the outdoor temperature is too low for proper compressor operation, cooling operation will be suspended. Similarly, heat pump heating operation will cease and the unit will automatically switch over to electric heating mode until the outdoor temperature rises to an acceptable point, depending upon the application.

Indoor Temperature Limiting (Keypad Control Only)

Using the keypad control and display, high and low temperature limits can be established to prevent the user from entering set point temperatures colder or warmer than what the property manager or hotel operator may desire. The temperature limit choices are as follows:

Configuration Code	Low Limit (°F)	High Limit (°F)
R1	63	86
R2	65	86
R3	65	90
R4	67	88
R5	67	92
R6	69	90
R7	69	72

The procedure to set the limits is as follows:

Depress the On/Off key, the °F/°C key, and the Warmer key simultaneously for 5 seconds to enter the limit setup mode. The Warmer and Cooler keys will scroll through the R-values indicated in the above table. Once the desired R-value has been obtained on the display, press the On/Off key to accept the change, and then press it again to effect the change and restore the normal display.

TROUBLESHOOTING GUIDE

SYMPTOM	CAUSE	CHECK / CORRECTION
No Cooling	System switch set to OFF or HEAT on wall thermostat (remote thermostat units only)	Switch to COOLING or AUTO
	System set to OFF at Keypad	Press On/Off key to turn unit ON, then press the COOL Key.
	System set to HEAT at Keypad	Press the COOL Key.
	Faulty thermostat (remote thermostat units only).	Test and replace if necessary.
	Fuse or circuit breaker tripped.	Replace or reset as necessary.
	No power to unit.	Have Qualified service personnel wire unit.
	Defective keypad, display, or main board.	Contact qualified service personnel.
	DIP switch improperly set on electronic board.	Contact qualified service personnel. Review specific wiring diagram.
	Indoor room temperature is below set point.	If comfort is not yet achieved, lower the thermostat setting (if using a remote thermostat), or depress the COOLER key on the keypad (in non-remote), as applicable.
Outdoor temperature too low	Unit is outside range of operation. Outdoor temperature must warm up before cooling operation can resume.	
No Heating	System switch set OFF on wall thermostat (remote thermostat units only)	Switch to HEATING or AUTO
	System set to OFF at Keypad	Press On/Off key to turn unit ON, then press the HEAT Key.
	Faulty thermostat (remote thermostat units only).	Test and replace if necessary.
	Fuse or circuit breaker tripped.	Replace or reset as necessary.
	No power to unit.	Have Qualified service personnel wire unit.
	Defective keypad, display, or main board.	Contact qualified service personnel.
	Indoor room temperature is above set point.	If comfort is not yet achieved, raise the thermostat setting (if using a remote thermostat), or depress the WARMER key on the keypad (for non-remote), as applicable.
	Defective heater.	Contact qualified service personnel.
	DIP switch improperly set on electronic board.	Contact qualified service personnel. Review specific wiring diagram.
	One-shot thermal fuse is blown.	Contact qualified service personnel.
	Automatic reset high limit control will not reset.	Contact qualified service personnel.
	Applicable Aquastat low voltage wires not jumpered, as required, if no aquastat is used (hydronic units only).	Review specific wiring diagram.
	Defective aquastat (hydronic units only).	Replace as required.
	No hot water supply (hydronic units only).	Contact qualified service personnel.
	DIP switch improperly set on electronic board (hydronic units only).	Contact qualified service personnel. Review specific wiring diagram for addressing “Normally Open” vs. “Normaly Closed” Hydronic Valves.
	Broken, shorted, loose, or incorrect wiring.	Contact qualified service personnel.
	Compressor is defective (heat pump only)	Remove front cover and locate the emergency heat switch. Switch to EMERGENCY HEAT as directed by the label located adjacent to the switch – this will activate the electric heater if there is a heating demand. Contact qualified service personnel to deal with the compressor repair.
Compressor is defective (heat pump only, remote thermostat only)	The wall thermostat may have an EMERGENCY HEAT setting. Select this switch setting - this will activate the electric heater if there is a heating demand. Contact qualified service personnel to deal with the compressor repair.	

No Fan Operation	System switch set to OFF on wall thermostat (remote thermostat units only)	Switch to LOW FAN, HIGH FAN, or FAN ON, as applicable.
	With system set to OFF on keypad, Fan is set to AUTO at Keypad.	Press FAN key to cycle through FAN LOW, FAN HIGH, and AUTO. Select the fan setting as desired. FAN AUTO will keep the fan off if the ON/OFF key is set to OFF.
	Defective fan motor	Contact qualified service personnel.
	Faulty thermostat (remote thermostat units only).	Test and replace if necessary.
	Fuse or circuit breaker tripped.	Replace or reset as necessary.
	No power to unit.	Have Qualified service personnel wire unit.
	Defective keypad, display, or main board.	Contact qualified service personnel.
Remote Thermostat does not Properly Control Room Temperature, Causes Unit to Run Continuously, or Causes Abnormal Cycle Times	Unwanted source of heating or cooling is near the wall thermostat causing the thermostat to sense a temperature other than room temperature (remote thermostat units only).	Eliminate the unwanted heating or cooling source or move the wall thermostat. See if thermostat is too close to a supply air register. Seal the hole in the wall where the thermostat cable passes into the thermostat.
	Wall thermostat body may be heating up due to impingement of direct sunlight, at a certain time of day.	Relocate thermostat, provide shade for the thermostat, or just live with the problem if it occurs for only a short time during the day.
	Defective thermostat.	Test and replace if necessary.
	DIP switch improperly set on electronic board.	Contact qualified service personnel. Review specific wiring diagram.
Keypad controls do not Properly Control Room Temperature, Causes Unit to Run Continuously, or Causes Abnormal Cycle Times in Heating or Cooling Mode	Air seals in wall sleeve are worn out, or completely missing. This allows outdoor air to be blended with indoor return air and the indoor temperature probe detects the erroneous blended temperature.	Take whatever steps are necessary to correct chassis-to-sleeve leakage. Contact qualified service personnel.
	Defective keypad, display, or main board.	Contact qualified service personnel.
Compressor Short-Cycles	Restricted outdoor coil.	Check for dirt or other outdoor coil restriction. Clean as necessary.
	Recycling of outdoor air	Check for inadequate outdoor air installation clearances. Outdoor coil may not be sealed against outdoor grille causing hot discharge air to be recirculated back into the condenser air intake. Contact qualified service personnel to correct condition.
	Recycling or blockage of indoor air causing frosting of indoor coil. Frosting of indoor coil can cause compressor short-cycling.	Ensure that curtains or other obstructions are not blocking the indoor air inlet, indoor air outlet, or creating a pocket to short-circuiting indoor air from the outlet grille to the return air intake.
	Dirty air filter.	Clean or replace
	Dirty evaporator coil.	Clean as necessary.
	Fan motor(s) operating intermittently, rotating slowly, or not at all.	Contact qualified service personnel.
	Faulty thermostat (remote thermostat units only).	Test and replace if necessary.
	Indoor coil freezing.	See "Indoor Coil Frosts"
	Indoor room temperature too cold.	Compressor will cycle on and off at the command of indoor coil frost control thermostat.
	Outdoor temperature too cold.	Compressor is not intended to operate at cold outdoor temperatures. Compressor operation will be locked out until the outdoor temperature rises, or compressor will cycle on and off at the command of the frost control devices.
	Defective keypad, display, or main board.	Contact qualified service personnel.

Unit Trips Fuse or Circuit Breaker	Shorted or incorrect wiring.	Contact qualified service personnel.
	Fuse or breaker setting too low.	Check nameplate fuse size.
	Low voltage	Check voltage with unit running and ensure it is within nameplate limits.
	Seized, noisy, or slow running compressor.	Contact qualified service personnel.
	Defective keypad, display, or main board.	Contact qualified service personnel.
Indoor Coil Frosts	Dirty air filter.	Clean or replace.
	Dirty indoor coil.	Clean as necessary.
	Blower motor operating intermittently, rotating slowly, or not at all.	Contact qualified service personnel.
	Recycling or blockage of indoor air causing frosting of indoor coil. Frosting of indoor coil can cause compressor short-cycling.	Ensure that curtains or other obstructions are not blocking the indoor air inlet, indoor air outlet, or creating a pocket to short-circuiting indoor air from the outlet grille to the return air intake.
	Defective suction line thermostat.	Contact qualified service personnel.
	Low refrigerant charge.	Look for telltale signs of low charge. During cooling operation, check frosting pattern starting from defrosted condition. If the whole indoor coil face frosts uniformly at the same time, it indicates that the unit has insufficient indoor airflow. If frost works its way up the face of the evaporator during operation over time, it indicates low charge. Contact qualified service personnel.
Heater Output Intermittent or Insufficient	Faulty thermostat.	Test and replace if necessary.
	Automatic reset high limit control defective.	Replace high limit.
	Dirty air filter.	Clean or replace
	Dirty evaporator coil.	Clean as necessary.
	Defective main board	Contact qualified service personnel.
	Blower motor operating intermittently, rotating slowly, or not at all.	Check if blower wheel or shaft is being rubbed or experiencing external friction. Check free rotation of the motor shaft. Check voltage to motor. Check motor capacitor. Check for miswiring. Replace motor, if necessary.
Water Drips from Unit	Sleeve not properly mounted.	Check sleeve for the required ¼" per foot pitch down from indoor to outdoor side and level side-to-side. Readjust as required.
	Condensate drain plugged.	Clean condensate drain.
	Evaporator drain pan leaky.	Inspect, repair or replace drain pan as required.
	Unusually high moisture content in the indoor and/or outdoor air.	Under certain indoor and outdoor conditions, excessive condensate is generated beyond the rate at which the unit can reject to the outdoor air stream by evaporation.
	Drain holes plugged in bottom edge of sleeve on outdoor side.	Inspect and clear blockage.

Model Nomenclature:

<u>J</u>	<u>E</u>	<u>C</u>	<u>09</u>	<u>G</u>	<u>25</u>	<u>E</u>	<u>0</u>	<u>N</u>	<u>A</u>	
Model Series										Branding
.....										Any Letters A-Z
									

E = Electric Heat / Cool
W = Hydronic Heat

C - R410A

CAPACITY

07 = 7,000 BTUh
09 = 9,000 BTUh
12 = 12,000 BTUh

VOLTAGE

N=208V - 1 - 60
G=230- 1 - 60
R=277V - 1 - 60

N= NO F/A DAMPER
P= POWER DAMPER

Cord and Plug Ratings
0 = NO CORD

OPTIONS

E = Electronic Controls

HEATER KW

00 = no heater
25 = 2.8 KW @208V
34 = 3.4 KW @208V
25 = 2.4 KW @230V
34 = 3.4 KW @230V
25 = 2.5 KW @277V
34 = 3.2 KW @277V

